

# Three Phase Power Calibrator and Tester



Calibrator / tester C300 is used for adjusting, checking and verification of measuring instruments used in power engineering. These include electricity meters, frequency, voltage and current protective relays, current transformers and clamps, active and reactive power meters, phase meters, frequency meters, ammeters, voltmeters, transducers, monitoring systems and power quality analyzers.

Calibrator C300 is three / one phase source of AC current and voltage with accuracy class 0,05% and programmable value of harmonics. It generates voltage up to 500V in sub ranges 60-130-250-500V, current up to 100A in sub ranges 0,5-6-20-100A, frequency in range 40...500Hz and phase shift in range  $0... \pm 360^\circ$ . In one phase connection it can generate current up to 300A.

Calibrator C300 has possibility to get error characteristics of tested equipment in function of measurement value and time characteristics of protection relays in automatic way. For electricity meter testing is used impulse input S0 standard with possibility of photo scanning head connection. Testing of transducers, current transformers and clamps is made by means of DC input with ranges 10V/20mA and AC input with ranges 10V/100mA/5A. For protective relay testing are used three timers with start/stop inputs and resolution 1ms. Two additional binary outputs are used for operate/standby calibrator state signalling.

Calibrator is controlled by means of personal computer with installed software *Calpro 300* in Windows operating system.

Calibrator is constructed in a standard 19" rack-mount size case.

C300 3- phase source up to 100A (1- phase up to 300A) and 500V

## C300 Three and One Phase Power / Energy Calibrator and Tester

- Voltage source up to 500V
- 3- phase current source up to 100A and 1- phase up to 300A
- Voltage and current harmonics programming up to 31
- Power quality parameters simulation
- Impulse input for electricity meters testing
- Start / stop inputs for protective relay testing
- AC measurement input for transformers and clamps testing
- DC measurement input for transducer testing
- RS232C interface and personal computer software Calpro 300

### CALPRO 300 Software features:

- base version:
  - setting the value of  $U+I+\phi+f+P+Q+S$ ,
  - harmonics U+I amplitude and phase shift setting,

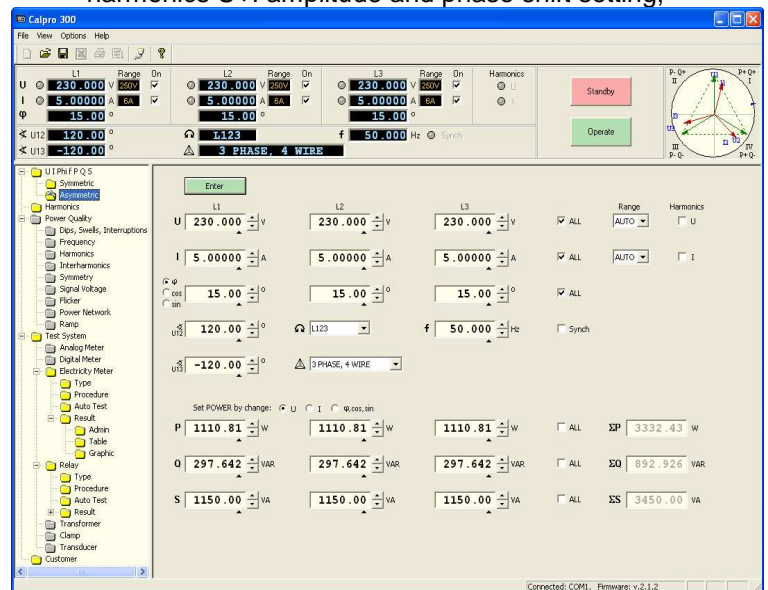

- base + TS (Test System) version:
  - automatic testing of electricity meters, protection relays, current transformers, current clamps, measurement transducers and computer aided testing of analogue and digital meters, computer data base of customers, meters, measurement procedures and results, diagrams, tables of results and reports edition,
- base + PQ (Power Quality) version:
  - power quality parameters programming.

### calmet Ltd.

Poland, 65-463 Zielona Góra, Fabryczna 23B, Tel. +48 68 324 04 56 Fax +48 68 324 04 57  
 e-mail: [mail@calmet.com.pl](mailto:mail@calmet.com.pl) internet: <http://www.calmet.com.pl> C300 data sheet 2009-11

# TECHNICAL PARAMETERS OF C300 CALIBRATOR

Parameter	Range	Setting range	Resolution	Accuracy	Maximum Load
Voltage U	60V	0,5000...60,0000V	0,0001V	±0,04% of setting ±0,01% of range	460mA@60V
	130V	1,000...130,000V	0,001V		230mA@130V
	250V	2,000...250,000V	0,001V		115mA@250V
	500V	5,000...500,000V	0,001V		55mA@500V
Current I	0,5A	0,005000...0,500000A	0,000001A	±0,04% of setting ±0,01% of range	15V@0,5A
	6A	0,05000...6,00000A	0,00001A		7V@6A
	20A	0,2000...20,0000A	0,0001A		2,2V@20A
	100A	1,000...100,000A	0,001A		1,0V@50A 0,7V@100A
Frequency f		40,000...99,999Hz	0,001Hz	±0,002Hz	
		100,000...500,000Hz	0,001Hz	±0,01Hz	
Phase shift φ		0,00...±360,00°	0,01°	±0,1° *)	
Active Power P		0...3x50000,0W	0,00001-1W	±0,05% *,**)	
Reactive Power Q		0...3x50000,0var	0,00001-1var	±0,05% *,**)	
Apparent Power S		0...3x50000,0VA	0,00001-1VA	±0,05%	
Time		1...36000s	1s	±0,01% ±0,001s	
Energy	calc. from settings and resolution of power and time			±0,05% *,**)	
Harmonics	amplitude and phase of harmonics in range 0...100% and 0...360° up to 31 of harmonics or 3200Hz				

\*) from 10% of current range, in frequency band 45-65Hz  
 \*\*) power P (Q) error for cosφ (sinφ) = 1

Specifications of calibrator's inputs for automatic tests		
S0 impulse input for counting impulses from electricity meter or photo scanning head (S0 impulse input)	input voltage and current range	S0 (DIN43864) or 0...2V/4...30V
	impulses frequency	up to 100Hz
	impulses counting time	0...999,999s
	number of counted impulses	0...99999
DC measurement input (Idc ammeter input and Udc voltmeter input)	input voltage and current range	0...10,0000V or 0...20,000mA
	error of measurement	0,02% of range
AC measurement input (Iac ammeter input and Uac voltmeter input)	input voltage and current range	0...10,000V or 0...100,00mA or 0...5,000A
	error of measurement	0,1% of range
Start/stop input for time measurement (Timer input t)	number of inputs	3
	time measurement	range 0,001...100,000s error 0,001s
	input voltage range	15...250V DC/AC
Binary outputs operate/standby for calibrator state signalling	number of inputs	2
	settling time	0,001s
	output load	100Vac/130Vdc/100mA

General parameters	
Weight and dimensions (width x height x depth)	34kg and (478x194x490)mm
Power supply	230V±10% / 45...65Hz / 700VA

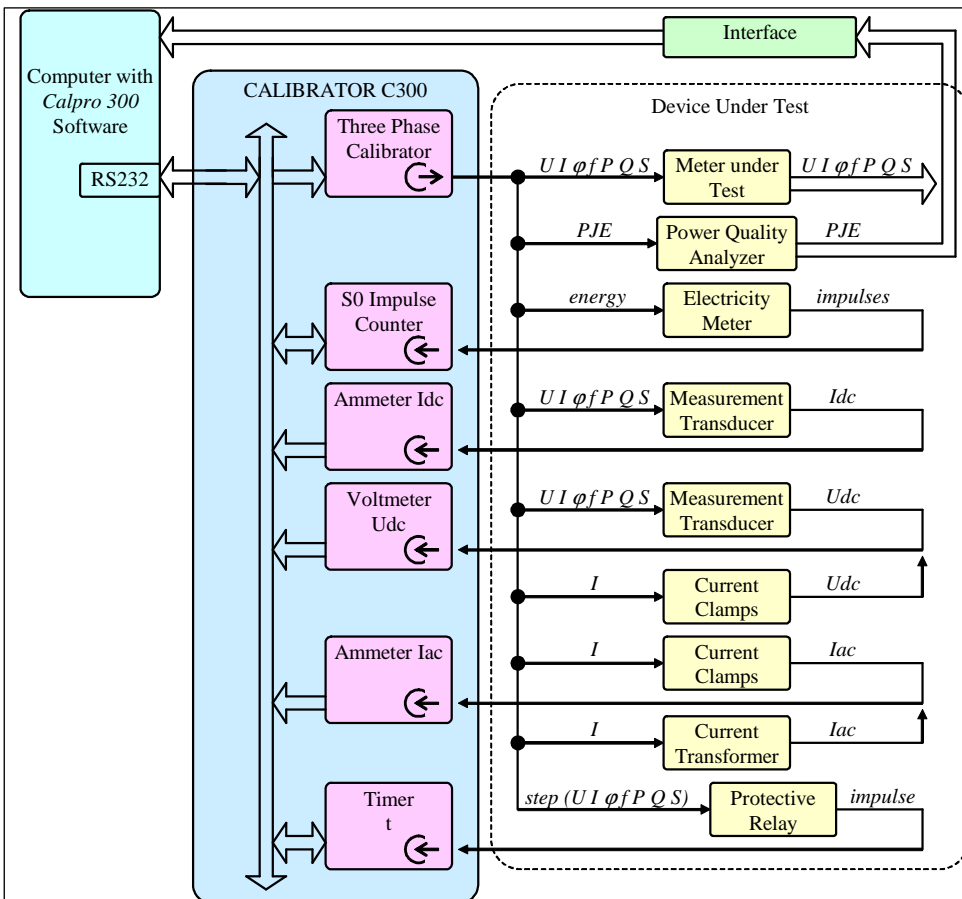

## AUTOMATIC TESTING SYSTEM consists of:

- C300 Calibrator / Tester,
- computer with Calpro 300 soft,
- device under test.

C300 Calibrator has three phase generator with accuracy 0.05% and auxiliary measurement inputs:

- S0 impulse counter for impulses from electricity meter or photo scanning head,
- ammeter for DC current measurement Idc from the output of measurement transducer,
- voltmeter for DC voltage measurement Udc from the output of measurement transducer or current clamp
- ammeter for AC current measurement Iac from output of current transformer or clamps,
- timer for protective relays switching time measurements